

# AerPro™ Oil Mist Collection Systems

AerPro™ Centrifugal Mist Collectors provide efficient collection of coolant mist and smoke. AerPro's control of in-plant airborne contaminant levels improves worker productivity while reducing facility maintenance costs.

## C-500 Features & Benefits

- **500 CFM (849.50m<sup>3</sup>/hr.) air flow capacity**  
Provides centrifugal collection for industrial filtration applications.
- **Sturdy, compact housing**  
Made of 16 gauge steel for durability and long service life.
- **1 HP motor/blower**  
Provides up to 3450 RPM at 60Hz for maximum collection efficiency.
- **Tight tolerance drum-and-cover design**  
Small gap between cover and drum ensures air flow through drum, optimizing efficiency.
- **Low noise operation**  
72 dBA noise level improves worker comfort.
- **Coated, perforated rotating drum**  
Prevents rust in water soluble applications.
- **Direct mount capability**  
Reduces need for unsightly ductwork.



### C-500

*The C-500, with air flow levels to 500 CFM (849.50m<sup>3</sup>/hr.), provides efficient coolant mist collection and filtration. Shown with optional in-cover pre-filter trap.*



### C-1000

*The C-1000 provides high volume contaminant collection up to 1000 CFM (1700m<sup>3</sup>/hr.) for applications using petroleum-based, synthetic, or water-soluble coolant. Shown with optional HEPA filter.*

## C-1000 Features & Benefits

- **1000 CFM (1700m<sup>3</sup>/hr.) air flow capacity**  
Provides heavy-duty centrifugal collection for high volume industrial filtration applications.
- **Sturdy, compact housing**  
Made of 16 gauge steel for durability and long service life.
- **3 HP motor/blower**  
Provides up to 3450 RPM at 60Hz for maximum collection and filtration efficiency.
- **Tight tolerance drum-and-cover design**  
Small gap between cover and drum ensures air flow through drum, optimizing efficiency
- **Low noise operation**  
74 dBA noise level improves worker comfort.
- **Coated, perforated rotating drum**  
Prevents rust in water soluble applications.
- **Direct mount capability**  
Reduces need for unsightly ductwork.

# C-500 & C-1000

## C-500 Product Specifications

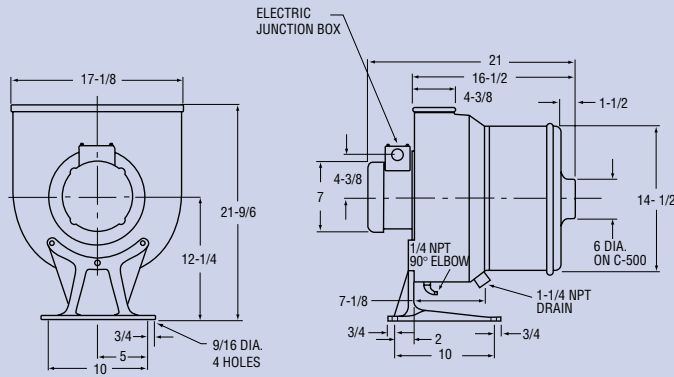

Height .....21-9/16" (548mm)  
 Width .....17-1/8" (435mm)  
 Depth .....21" (533mm)

Air flow ..... 450 CFM (765m<sup>3</sup>/hr.) at 50Hz  
 500 CFM (849.50 m<sup>3</sup>/hr.) at 60Hz  
 Construction ..... 16 gauge steel with oil resistant paint  
 Weight ..... 95 lbs. (43 kg)  
 Sound Level ..... 72 dBA  
 Motor/Blower ..... 1 HP, 3450 RPM at 60Hz  
 (0.75KW, 3450 RPM at 60Hz)  
 1 HP, 2850 RPM at 50Hz  
 (0.75KW, 2850 RPM at 50 Hz)  
 Color ..... LevCo™ Blue  
 Electrical ..... 230/460VAC, 60Hz 3-phase,  
 TEFC 190/380VAC, 3-phase 50Hz

### Options:

- **In-cover Pre-filter**  
Prevents damaging materials from entering centrifugal drum.
- **Pedestal Mounts**  
Floor-mount system for use when machine mounting is either impractical or unnecessary.
- **Electrical Control Box**  
Allows for remote operation.
- **After-filter**  
95% DOP, or HEPA.  
Carbon odor module.

## C-1000 Product Specifications

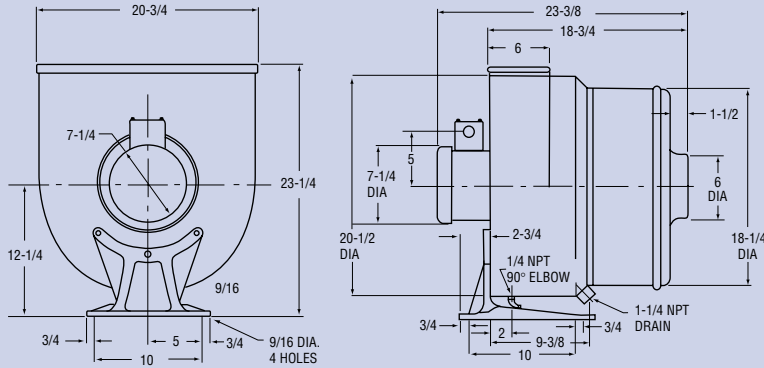

Height .....23-1/4" (590mm)  
 Width .....20-3/4" (527mm)  
 Depth .....23-3/8" (592mm)

Air flow ..... 900 CFM (1530m<sup>3</sup>/hr.) at 50Hz  
 1000 CFM (1700m<sup>3</sup>/hr.) at 60Hz  
 Construction ..... 16 gauge steel with oil resistant paint  
 Weight ..... 120 lbs. (60 kg)  
 Sound Level ..... 74 dBA  
 Motor/Blower ..... HP, 3450 RPM at 60Hz  
 (2.2KW, 3450 RPM at 60Hz)  
 3 HP, 2850 RPM at 50Hz  
 (2.2KW, 2850 RPM at 50Hz)  
 Color ..... LevCo™ Blue  
 Electrical ..... 230/460VAC, 60Hz 3-phase,  
 TEFC 190/380VAC, 3-phase 50Hz

### Options:

- **In-cover Pre-filter**  
Prevents damaging materials from entering centrifugal drum.
- **Pedestal Mounts**  
Floor-mount system for use when machine mounting is either impractical or unnecessary.
- **Electrical Control Box**  
Allows for remote operation.
- **After-filter**  
95% DOP, or HEPA.  
Carbon odor module.

Distributed by:

Industrial Air Quality, Inc  
 Youngsville, NC  
 P: 800-232-9559  
 919-562-7181  
 F: 919-562-7182  
 info@iaqsales.com